

Re: Final Copies of Bonding Clamp Installation Instructions

March 18, 1999

Ms. Marlene Kurz
Vice President
A. K. Stamping Company, Inc.
1159 US Route 22
Mountainside, NJ 07092
Tel: (908) 232-7300 x231
Fax: (908) 232-4729

Dear Marlene,

Telcordia (formerly Bellcore) has completed the development of the Installation Instructions for the A.K. Stamping Bond Clamps according to Telcordia Service Order contract 8YSCG4. Enclosed are 20 printed copies of the final Installation Instructions. Under separate cover, Ken Moyers will also be providing an electronic copy of the document file.

It has been a pleasure working with you on this project. I look forward to a continued beneficial working relationship for both of our companies.

Sincerely,



Charles L. Walker
Project Director - Network & Product Integrity and Reliability

Enclosures: (20 Copies) "A. K. Stamping Bond Clamps, Installation Instructions"

cc:

Peter Buonfiglio	MCC 1C167G	Ken Moyers	NVC 3X277
Leland Key	Reading, PA	Kevin Pearce	PYA 3B210

A. K. STAMPING BOND CLAMPS

INSTALLATION INSTRUCTIONS

CONTENTS	PAGE
1. GENERAL -----	2
2. DESCRIPTION -----	3
B Bond Clamp -----	4
Mini B And Canadian Mini Bond Clamps-----	4
D Bond Clamp -----	5
Gator Clamp -----	6
Small Gator Clamp -----	6
3. INSTALLATION OF BOND CLAMPS -----	7
B, Mini B, And Canadian Mini Bond Clamps -----	7
D, Gator, And Small Gator Bond Clamps -----	10
Summary of Bond Clamp Application and Installation -----	11
4. INSTALLATION OF BOND STRAP -----	13
Preterminated Bond Strap -----	14
Braided Bond Strap -----	15
Unterminated Wire -----	17
Bonding Ribbon -----	18

**A. K. STAMPING BOND CLAMPS
INSTALLATION INSTRUCTIONS**

1. GENERAL

1.01 This document covers the description and installation of bond clamps manufactured by A. K. Stamping Company, Inc.; 1159 US Route 22; Mountainside, NJ 07092.

**TABLE A
A. K. STAMPING BOND CLAMPS**

Bond Clamp Designation	Fastener Hardware Supplied (1)	Part Number
B1 Bond Clamp	1 Locknut	400-366-332
B1 Bond Clamp	2 Locknuts	400366332-2N
B1 Bond Clamp	2 Locknuts, 1 Flat Washer	400366332BA
B1 Bond Clamp	2 Locknuts, 10-32 Thread	A1278
B2 Bond Clamp	1 Locknut	400-366-340
B2 Bond Clamp	2 Locknuts	400366340-2N
B2 Bond Clamp	2 Locknuts, 1 Flat Washer	400366340BA
B2 Bond Clamp	2 Locknuts, 10-32 Thread	A1279
B3 Bond Clamp	1 Locknut	400-366-357
B3 Bond Clamp	2 Locknuts	400366357-2N
B3 Bond Clamp	2 Locknuts, 1 Flat Washer	400366357BA
Mini B Bond Clamp	2 Locknuts	400366332MB-2N
Canadian Mini Bond Clamp	2 Locknuts	CMB123
D Bond Clamp	1 Locknut	400-963-757
D Bond Clamp	2 Locknuts	400963757-2N
D Bond Clamp	2 Locknuts, 1 Flat Washer	400963757BA
Gator Clamp w Shoe	2 Locknuts	A1037
Gator Clamp w/o Shoe	2 Locknuts	A1069
Small Gator Clamp w B1 Outer Plate	2 Locknuts	A1255
Small Gator Clamp w/o B1 Outer Plate	2 Locknuts	A1256 or 701-225-864
Small Gator Clamp w/o B1 Outer Plate (2)	2 Locknuts	A1257

(1) Locknuts are hex nuts with captured external tooth lock washers. Thread is 10-24 unless otherwise noted.

(2) Stud length 0.5 inches.

1.02 Whenever this document is reissued, the reason(s) will be listed in this paragraph.

<p style="text-align: center;">A. K. STAMPING BOND CLAMPS INSTALLATION INSTRUCTIONS</p>
--

1.03 A. K. Stamping Bond Clamps are designed to make a stable and low resistance electrical connection to the aluminum shield of plastic sheathed, metallic conductor and optical fiber cables. When connected to appropriate bonding straps, the bonding clamps have two functions: (1) restore the electrical continuity of the cable shield at cable splices; and (2) connect the cable shield to ground by connections to ground brackets in terminals and splice closures. The bonding of cable shields is an essential part of the electrical protection of the telephone plant and is necessary to reduce voltages and currents imposed by lightning and electrical power lines.

1.04 The maximum current carrying capacity of these clamps is equivalent to at least a No. 6 AWG copper conductor (50 amperes).

1.05 A. K. Stamping Bond Clamps may be used with either single or dual sheath cables in either exposed or unexposed plant.

2. DESCRIPTION

2.01 A. K. Stamping Bond Clamps consist of an inner plate with a threaded stud that is placed inside the cable shield and an outer plate placed over the stud and on top of the cable jacket. The bottom plate is serrated to ensure adequate electrical contact is made, even to coated aluminum shields; the top plate has raised teeth to ensure a secure connection to the cable jacket. Several combinations of hex nuts with captured lock washers and flat washers are available to clamp the two plates together and to attach a bond strap to the clamp. All parts are tin plated for low electrical contact resistance and are made from copper alloys for high conductivity. The use of similar materials for all parts prevents galvanic corrosion.

2.02 A. K. Stamping Bond Clamps are available in several styles and sizes as shown in Table A. The different clamp styles can frequently be used in similar applications and differ mainly in their installation procedures; selection in these cases is primarily based on local preference. However, some clamp styles and sizes must be matched to cable size as specified in the descriptions of the individual clamp styles.

A. K. STAMPING BOND CLAMPS INSTALLATION INSTRUCTIONS

B Bond Clamp

2.03 The B Bond Clamp is shown in Figure 1. It is available in three sizes for use with different sizes of cable as listed in the table below; the size designation is stamped on the outer plate. The stud on the bottom plate normally has a 10-24 thread, but it is also available with a 10-32 thread.

CLAMP STYLE	USE WITH CABLE DIAMETER
B1 Bond Clamp	Less than 0.9 inches
B2 Bond Clamp	0.9 to 1.6 inches
B3 Bond Clamp	Greater than 1.6 inches

The clamps can be ordered with the following fastener hardware as needed by local preference:

- 1 Hex nut with captured external tooth lock washer
- 2 Hex nuts with a captured external tooth lock washers
- 2 Hex nuts with a captured external tooth lock washers and a flat washer

Laboratory studies and experience have shown that acceptable installations can be made with any of these fastener combinations.



Figure 1 - B Bond Clamp

Mini B and Canadian Mini Bond Clamps

2.04 The Mini B Bond Clamp, shown in Figure 2, consists of an outer plate from a B1 bond clamp and a reduced size inner plate. The Canadian Mini Bond Clamp is similar to the Mini B Bond Clamp using the same inner plate but a

A. K. STAMPING BOND CLAMPS INSTALLATION INSTRUCTIONS

reduced size outer plate. Both clamps are recommended for cables less than 0.6 inches in diameter such as optical fiber cables. They are furnished with two hex nuts with captured external tooth lock washers.

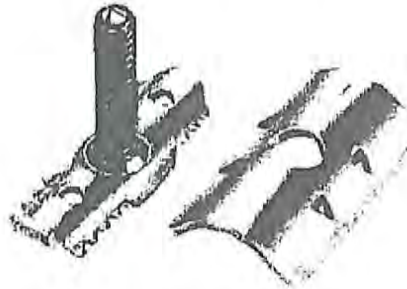

Figure 2 - Mini B Bond Clamp

D Bond Clamp

2.05 The D bond clamp, shown in Figure 3, is suitable for use on all cable sizes. It is a modified version of the B bond clamp that provides simpler installation because it does not require slitting of the cable jacket except for cables less than 0.9 inches in diameter or for cables with polyethylene foam skin insulated metallic conductors. This clamp can be ordered with the following fastener hardware as needed by local preference:

- 1 Hex nut with captured external tooth lock washer
- 2 Hex nuts with a captured external tooth lock washers
- 2 Hex nuts with a captured external tooth lock washers and a flat washer

Laboratory studies and experience have shown that acceptable installations can be made with any of these fastener combinations.



Figure 3 - D Bond Clamp

A. K. STAMPING BOND CLAMPS INSTALLATION INSTRUCTIONS

Gator Clamp

2.06 The Gator Bond Clamp, shown in Figure 4, is suitable for use on all cable sizes. It provides simpler installation than B bond clamps because it does not require slitting of the cable jacket except for cables less than 1 inch in diameter or for cables with polyethylene foam skin insulated metallic conductors. A plastic shoe, which facilitates installation of the bottom plate, is available. Use of the shoe also requires slitting of the cable jacket. This clamp is furnished with two hex nuts with captured external tooth lock washers.

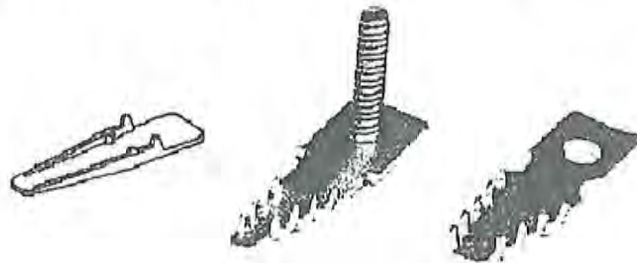

Figure 4 - Gator Clamp

Small Gator Clamp

2.07 The Small Gator Clamp, shown in Figure 5, is a reduced size version of the Gator Clamp and is recommended for cables less than 0.8 inches in diameter such as optical fiber cables. Like the Gator clamp, it also provides simpler installation than B bond clamps because it does not require slitting of the cable jacket except for cables less than 0.45 inches in diameter or for cables with polyethylene foam skin insulated metallic conductors. This clamp is furnished with two hex nuts with captured external tooth lock washers.

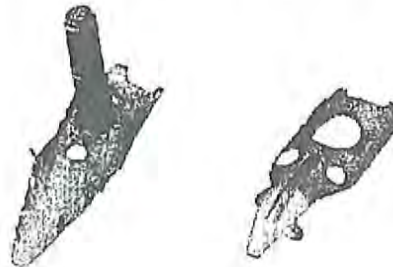

Figure 5 - Small Gator Clamp

<p style="text-align: center;">A. K. STAMPING BOND CLAMPS INSTALLATION INSTRUCTIONS</p>
--

3. INSTALLATION OF BOND CLAMPS

3.01 The installation of any style of bond clamp involves a similar sequence of steps. These steps are cable end preparation, insertion of the inner plate between the core wrap and the shield, and attachment of the outer plate. Recommended procedures for these steps are outlined in the subsequent sections.

B, MINI B, AND CANADIAN MINI BOND CLAMPS

3.02 All sizes of the B, Mini B, and Canadian Mini bond clamps use the same procedures for installation. The installation procedures will be illustrated with a B bond clamp (Figures 6 and 7).

3.03 Prepare the cable end by first removing the jacket and shield to expose a sufficient length of core for splicing; do not remove the core wrap at this time.

3.04 Using shears make a 1-1/2 inch long axial cut in the outer jacket and shield. Place two turns of vinyl tape over the core wrap adjacent to the cut in the sheath (Figure 6). For dual-sheath cable, remove 1/2 inch length of outer sheath prior to making 1-1/2 inch cut in outer jacket and shield (Figure 7).

3.05 Slide the inner clamp plate between the core wrap and the shield with the stud in the slit in the jacket until the bent tab on the end of the plate is even with the outer jacket. If a corrosive environment is present, beads of sealant should be applied to the end of the cut in the sheath. Wrap the cut jacket with two half-lapped layers of vinyl tape.

3.06 Place the outer clamp plate over the stud of the inner plate and tighten with a hex head nut with a captive external tooth lock washer. The nut requires a 3/8 wrench and should be tightened with a torque of 10 to 40 inch-pounds. A torque wrench can be used for tightening the nut but laboratory studies and experience show that a nut driver such as a 216-Type tool will apply an appropriate level of torque.

**A. K. STAMPING BOND CLAMPS
INSTALLATION INSTRUCTIONS**

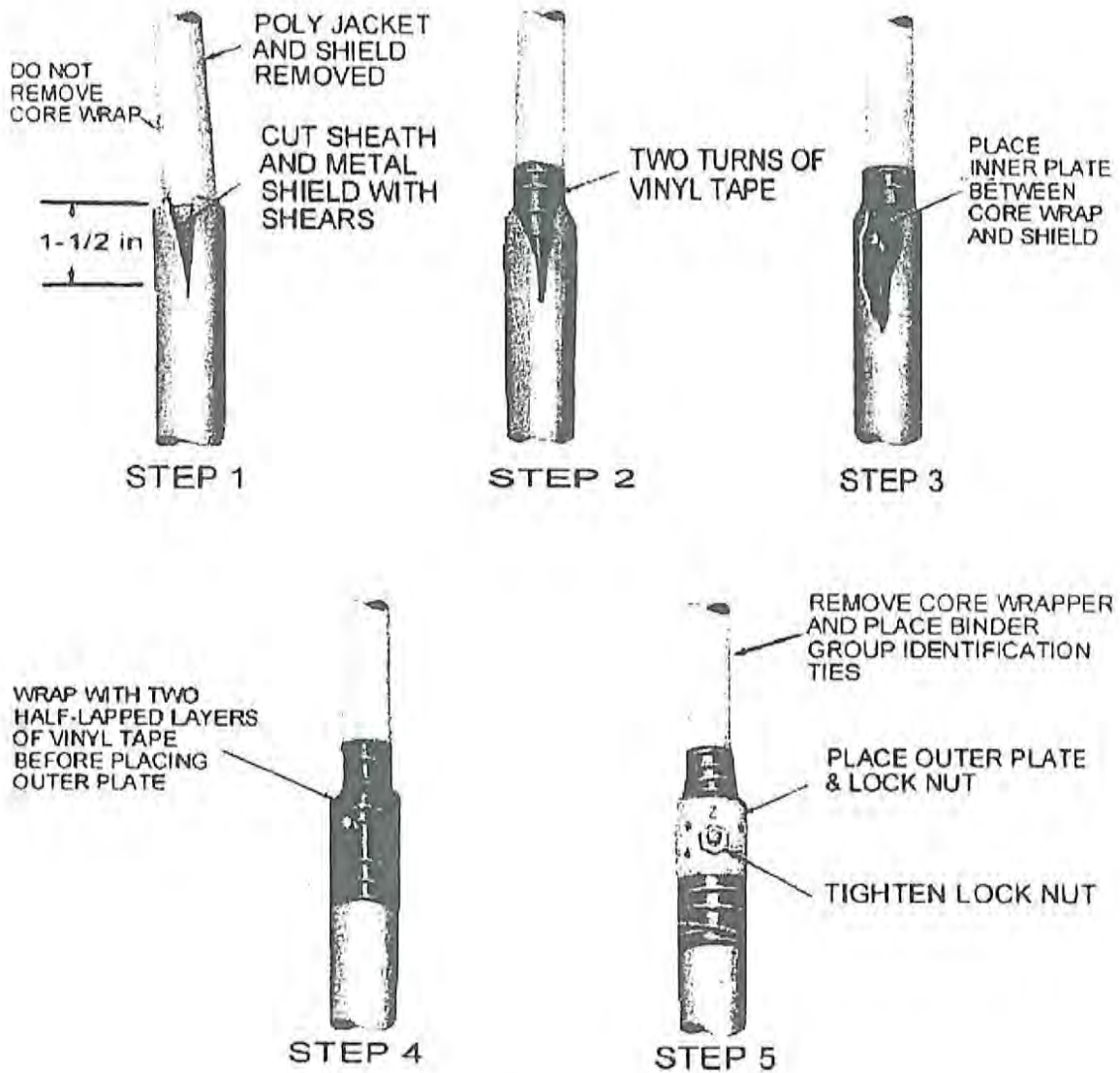

Figure 6 - Installing B Bond Clamp - Single Sheath Cable

A. K. STAMPING BOND CLAMPS
INSTALLATION INSTRUCTIONS

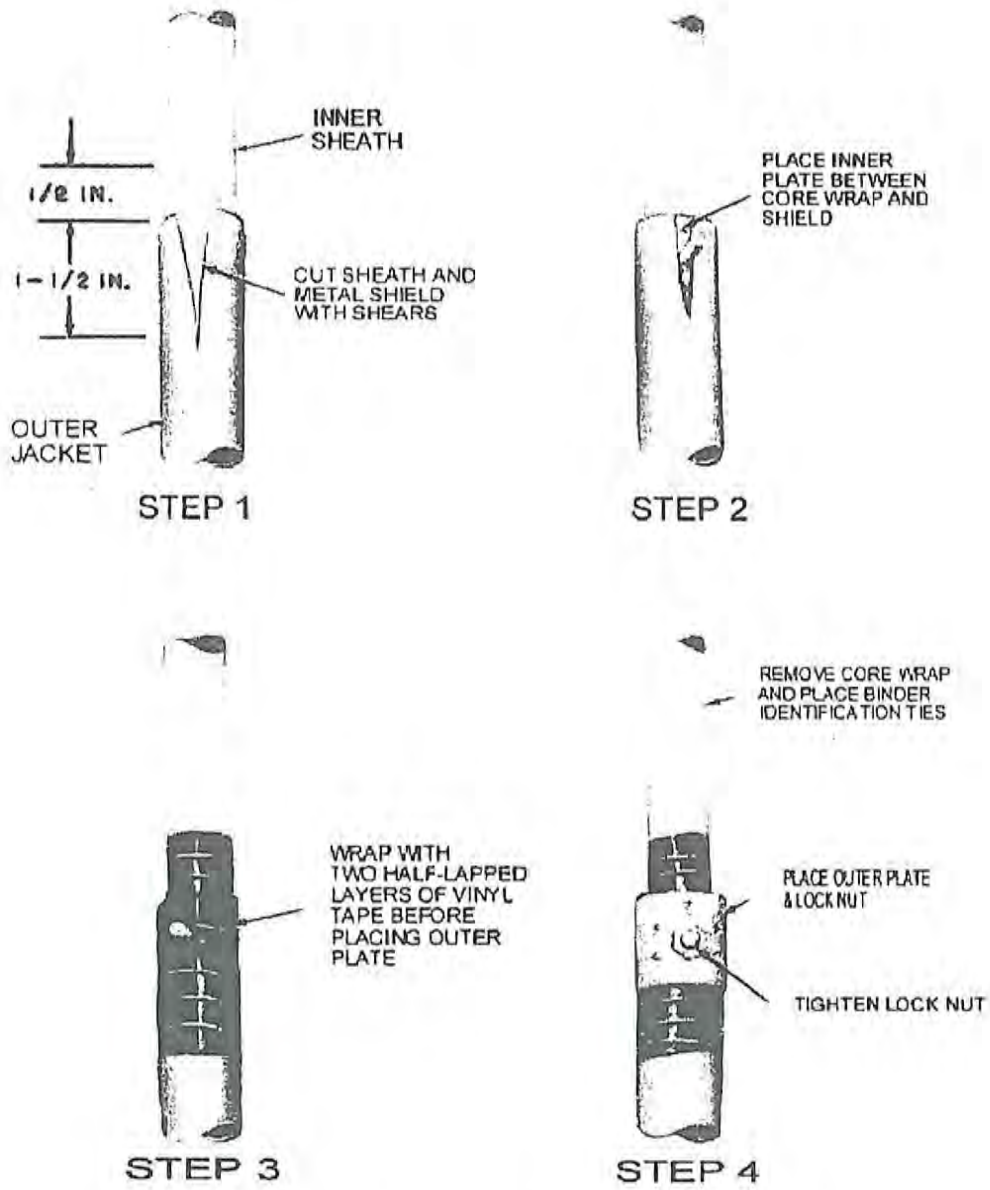

Figure 7 - Installing B Bond Clamp - Dual-Sheathed Cable

**A. K. STAMPING BOND CLAMPS
INSTALLATION INSTRUCTIONS**

D, GATOR, AND SMALL GATOR BOND CLAMPS

3.07 The D , Gator, and Small Gator Bond Clamps all use the same procedures for installation except for the length of jacket removal and jacket slits as described below. The installation procedures will be illustrated with a D bond clamp (Figure 8).

3.08 Prepare the cable end by first removing the jacket and shield to expose a sufficient length of core for splicing; do not remove the core wrap at this time.

3.09 Remove an additional length (L1) of the jacket and shield. For dual-sheath cable, remove a length (L1) of outer sheath. (L1 is shown on Figure 8.)

CLAMP STYLE	L1 (inches)
D Bond Clamp	1
Gator Clamp	1
Small Gator Clamp	3/4

3.10 For most cables the bond clamps can now be installed. However, for the following cables, an axial cut must first be made in the jacket and shield to allow easy insertion of the lower clamp plate between the core wrap and the shield:

- A. All metallic cables with polyethylene foam skin insulated conductors.
- B. Cables with a diameter less than shown in the following table:

CLAMP STYLE	CABLE DIAMETER (inches)
D Bond Clamp	0.8
GATOR CLAMP	1
SMALL GATOR CLAMP	0.45

In addition, an axial cut in the jacket and shield must be made **whenever** a bond shoe is used with a Gator clamp.

For any of the above conditions, use shears to make a cut of length L2 in the outer jacket and shield. (L2 is shown on Figure 8.)

CLAMP STYLE	L2 (inches)
D Bond Clamp	2
Gator Clamp	1
Small Gator Clamp	1

**A. K. STAMPING BOND CLAMPS
INSTALLATION INSTRUCTIONS**

3.11 For the D Bond Clamp, slide the inner plate between the core wrap and the shield until the stud butts against the outer jacket. For the Gator or Small Gator Clamp, slide the inner plate between the core wrap and the shield until the bent tabs on the inner shield butt against the outer jacket. If the jacket was slit (Paragraph 3.10), then the inner plate must be inserted 180 degrees from the slit. If a corrosive environment is present, beads of sealant should be applied to the end of the cut in the sheath. Wrap the cut jacket with two half-lapped layers of vinyl tape.

3.12 Place the outer plate over the stud of the inner plate and tap the portion of the outer plate over the jacket to assist in embedding the teeth into the jacket. Join the plates together with a hex head nut with a captive external tooth lock washer. The nut requires a 3/8 wrench and should be tightened with a torque of 10 to 40 inch-pounds. A torque wrench can be used for tightening the nut but laboratory studies and experience show that a nut driver such as a 216-Type tool will apply an appropriate level of torque. If the jacket was slit (Paragraph 3.10), then wrap the cut jacket with two half-lapped layers of vinyl tape.

3.13 SUMMARY OF BOND CLAMP APPLICATION AND INSTALLATION

TABLE B

CLAMP STYLE	USE WITH CABLE DIAMETERS	SHEATH SLIT REQUIRED FOR CABLE DIAMETERS	SHEATH SLIT NOT REQUIRED FOR CABLE DIAMETERS
B1 Bond Clamp	Less than 0.9 in	Less than 0.9 in	Not Applicable
B2 Bond Clamp	0.9 to 1.6 in	0.9 to 1.6 in	Not Applicable
B3 Bond Clamp	Greater than 1.6 in	Greater than 1.6 in	Not Applicable
Mini B Bond Clamp	Less than 0.6 in	Less than 0.6 in	Not Applicable
Canadian Mini B Bond Clamp	Less than 0.6 in	Less than 0.6 in	Not Applicable
D Bond Clamp	Any Diameter	Less than 0.9 in	Greater than 0.9 in
Gator Clamp	Any Diameter	Less than 1 in	Greater than 1 in
Small Gator Clamp	Less than 0.8 in	Less than 0.45 in	0.45 to 0.8 in

**A. K. STAMPING BOND CLAMPS
INSTALLATION INSTRUCTIONS**

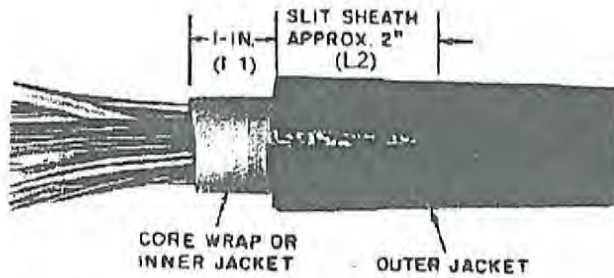

CABLE DIAMETER LESS THAN 0.9 IN.
SHEATH SLITTING REQUIRED 180° AWAY FROM POINT OF
INSERTION OF D BOND CLAMP.

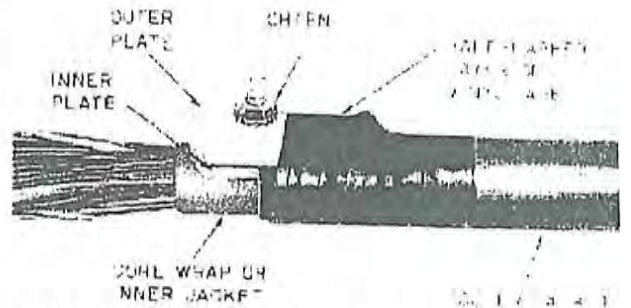

CABLE DIAMETER 0.9 IN OR LESS
(WRAP WITH VINYL TAPE APPROX. 1/2 IN.
PAST END OF SLIT)

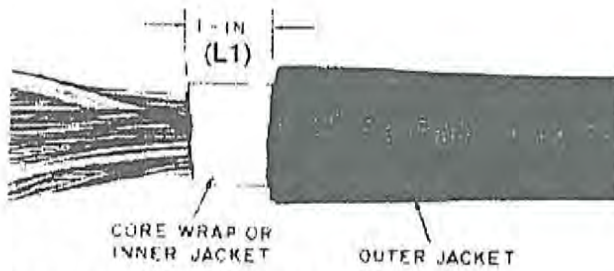

CABLE DIAMETER GREATER THAN 0.9 IN.
(SHEATH SLITTING NOT REQUIRED)

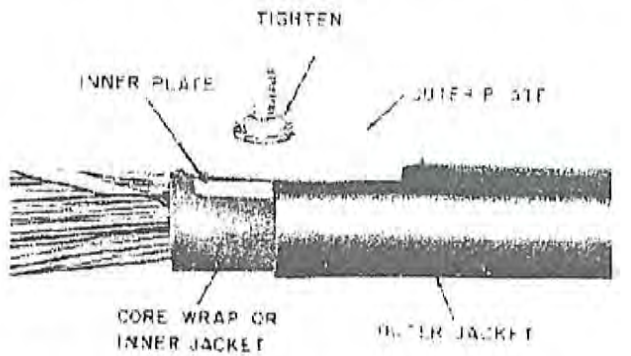

CABLE DIAMETER GREATER THAN 0.9 IN.

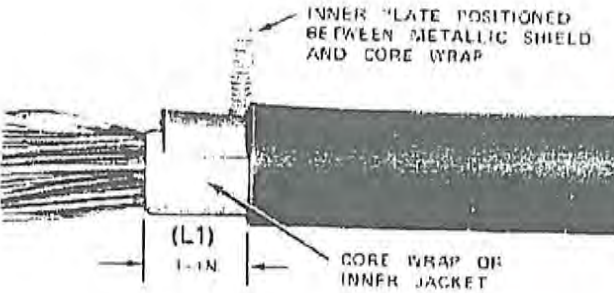

Figure 8 - Installing D Bond Clamp

4. INSTALLATION OF BOND STRAP

4.01 The bonding circuit is completed by attaching a bond strap between two bond clamps or between a bond clamp and a ground bracket on a terminal or closure. There are several types of bond straps available including stranded or solid copper wire terminated with copper terminals, flexible copper braid with eyelets, solid copper bonding ribbon, or solid, unterminated copper wire. A version of the D bond clamp is available with a ferrule on the inner plate to which a bond strap is attached. Examples of these bond straps are shown in Figure 9. Selection of a bonding strap is based upon local preference.



**Preterminated Stranded
Copper Bond Strap**



**Preterminated Solid
Copper Bond Strap**



Copper Braid With Eyelets



D Bond Clamp with Bond Strap

Figure 9 - Bond Straps

A. K. STAMPING BOND CLAMPS INSTALLATION INSTRUCTIONS

4.02 All straps must have a conductivity equivalent to at least a 6 AWG copper conductor (50 amperes).

Preterminated Bond Strap

4.03 Attach the terminal of the bond strap to the stud of a B, Mini B, Canadian Mini or D bond clamp using either one hex nut with a captured external tooth lock washer or two hex nuts with captured external tooth lock washers and a flat washer (Figure 10) in accordance with local preference. The preferred assembly method uses two nuts and a flat washer but laboratory studies and experience has shown that, if the nuts are tightened sufficiently (10 to 40 inch-pounds torque), the resultant installation will be satisfactory independent of the connection hardware

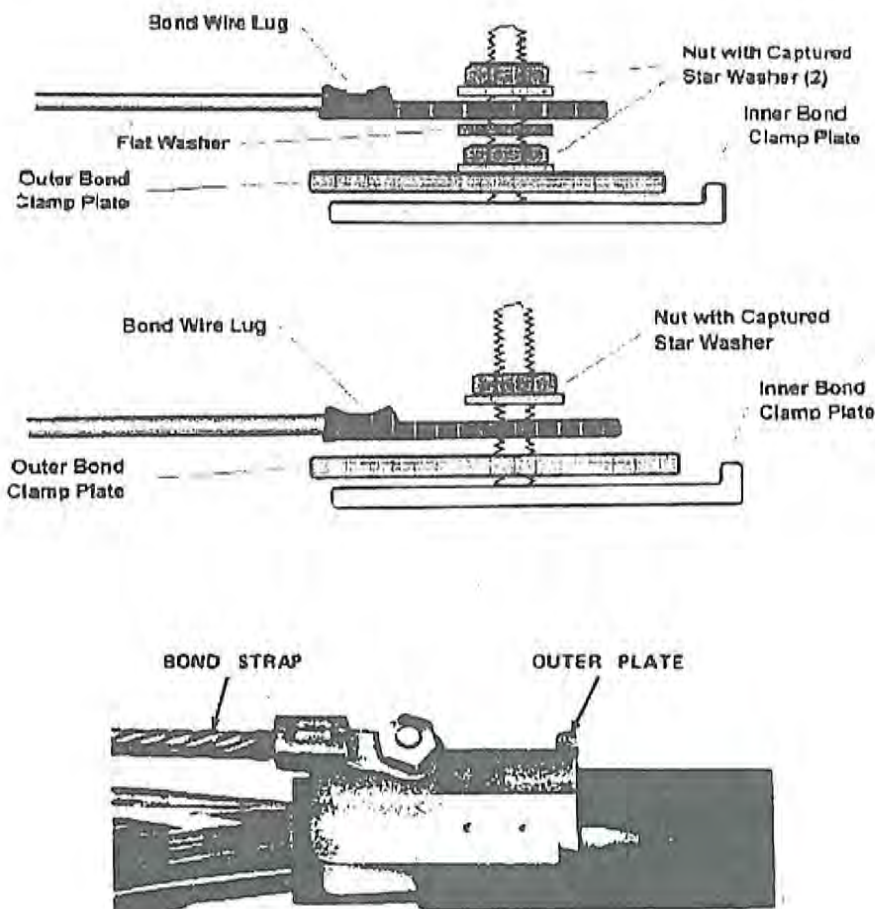

Figure 10 - Attaching Terminated Bond Strap to D Bond Clamp

A. K. STAMPING BOND CLAMPS INSTALLATION INSTRUCTIONS

4.04 Attach the terminal of the bond strap to the stud of the lower plate of a Gator or Small Gator clamp between the tail ends of the upper and lower plates (Figure 11). Be sure that the insulation on the bond wire is not pinched between the clamp plates. Secure the upper clamp plate with a hex nut with a captured external tooth lock washer. Tighten the nut with a torque of 10 to 40 inch-pounds.

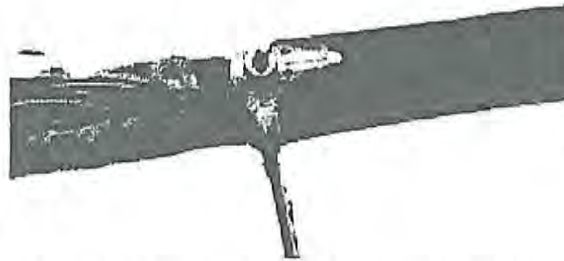

Figure 11 - Attaching Terminated Bond Strap to Gator Clamp

Braided Bond Strap

4.05 Attach braided bond **with** eyelets to the stud of style bond clamp using one nut with a captured external tooth lock washer to secure the outer clamp plate and a second similar nut with a captured lock washer to secure the bond strap (Figure 12). Tighten the nuts with a torque of 10 to 40 inch-pounds.

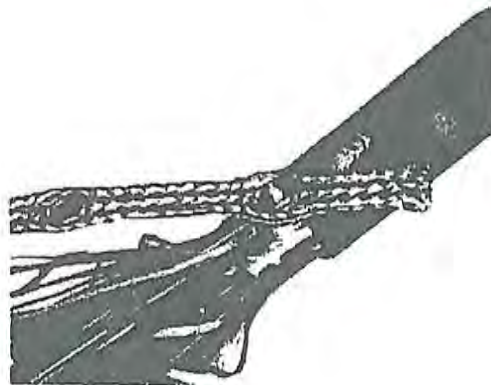

Figure 12 - Braided Bond With Eyelets Attached to Small Gator Clamp

A. K. STAMPING BOND CLAMPS INSTALLATION INSTRUCTIONS

4.06 Attach braided bond **without** eyelets to the stud of a B, Mini B, Canadian Mini, or D bond clamp using an outer plate from a B2 bond clamp (Figure 13). Secure the outer plate with a hex nut with a captured external tooth lock washer using a torque of 10 to 40 inch-pounds.

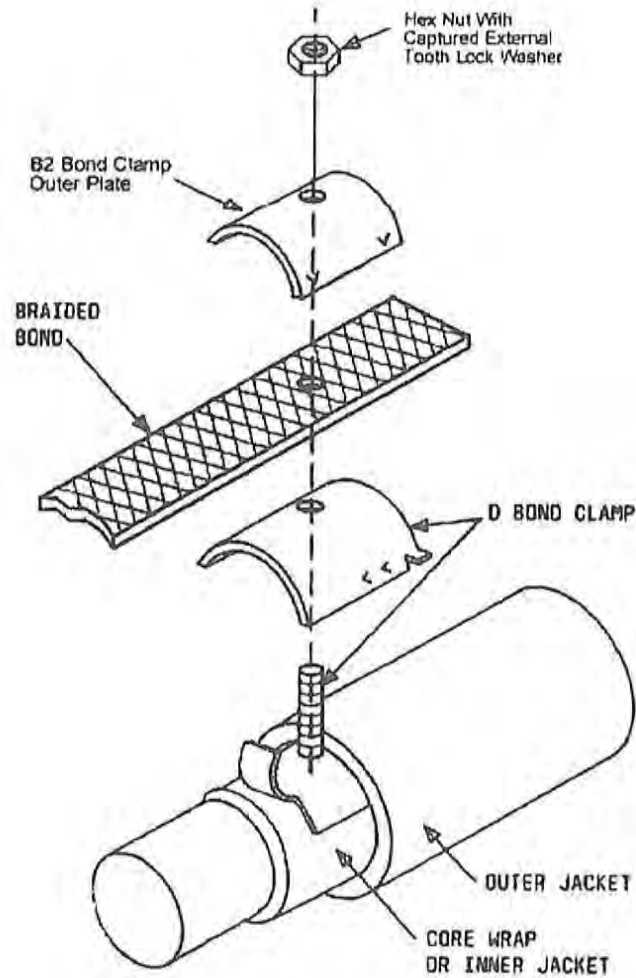

Figure 13 - Attaching Braided Bond Strap Without Eyelets to Bond Clamp

4.07 Braided bond strap without eyelets is not recommended for Gator or Small Gator bond clamps.

A. K. STAMPING BOND CLAMPS INSTALLATION INSTRUCTIONS

Unterminated Wire

4.08 Attach unterminated copper wire (6 AWG or larger) to a B, Mini B, Canadian Mini, or D bond clamp using an outer plate from a B2 bond clamp (Figure 14). Secure the outer plate with a hex nut with a captured external tooth lock washer using a torque of 10 to 40 inch-pounds.



Prepared Ground Wire Positioned
On a B2 Bond Clamp Outer Plate



Completed Ground Wire Installation

Figure 14 - Attaching Unterminated Wire to Bond Clamp

4.09 Unterminated wire is not recommended for Gator or Small Gator bond clamps.

A. K. STAMPING BOND CLAMPS INSTALLATION INSTRUCTIONS

Bonding Ribbon

4.10 Attach bonding ribbon to a B, Mini B, Canadian Mini or D bond clamp using an outer plate from a B2 bond clamp (Figure 15). Secure the outer plate with a hex nut with a captured external tooth lock washer using a torque of 10 to 40 inch-pounds.



PREPARED BONDING RIBBON



Completed Bonding Ribbon Installation

Figure 15 - Attaching Bonding Ribbon to Bonding Clamp

4.11 Bonding ribbon is not recommended for use with the Gator or Small Gator bond clamps.